



Set-up Instructions

WD90U-2/CN90U-2/WD90UR-2

ATV

Removal from crate



1. Remove cardboard carton from metal frame.

2. Remove operating instructions, manufacture statement of origin, and owners manual located on top of ATV.

3. Carefully remove metal frame

Handlebar Assembly

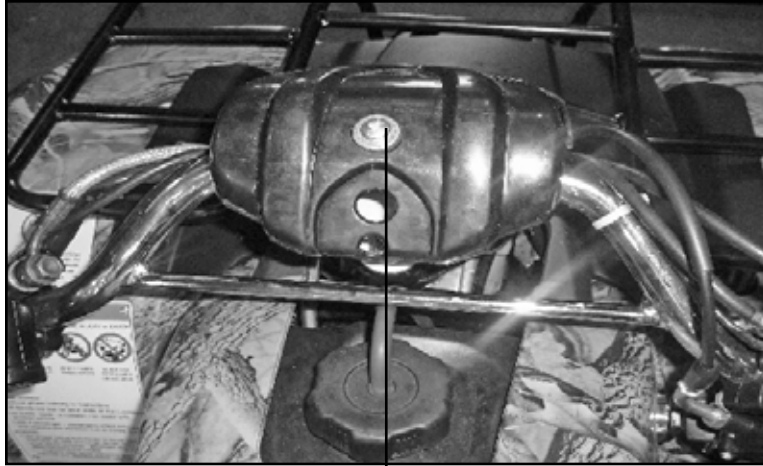

4. Loosen plastic guard bolt and remove plastic guard.

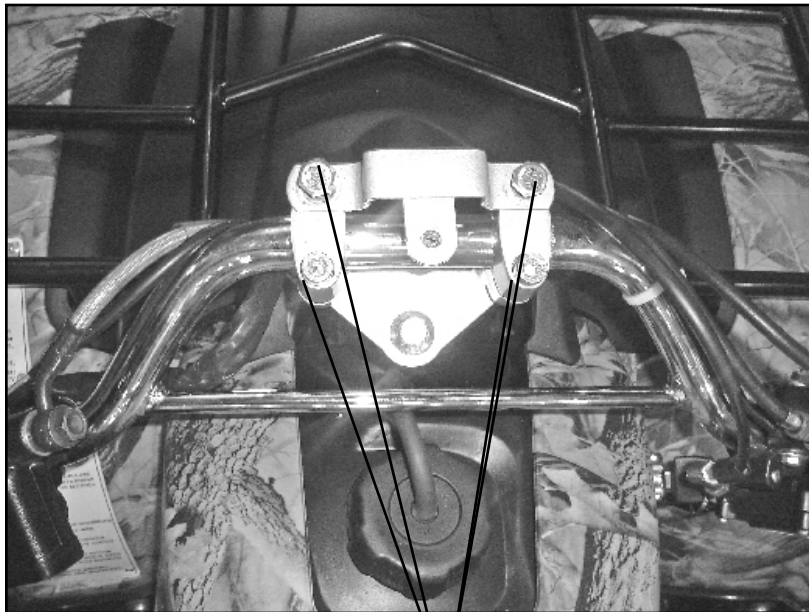

5. Loosen all bolts and lift handle bars to desired position, tighten handle bar bolt. Torque to 20 ft.lbs. Replace the plastic guard and tighten bolt.

Front Wheels

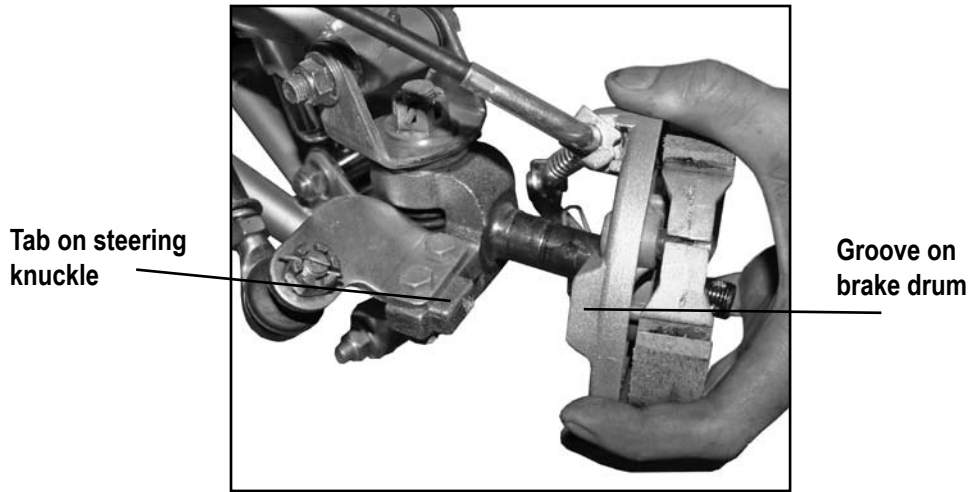

6. Attach front brake drum to steering knuckle. Align groove on brake drum with tab on steering assembly.

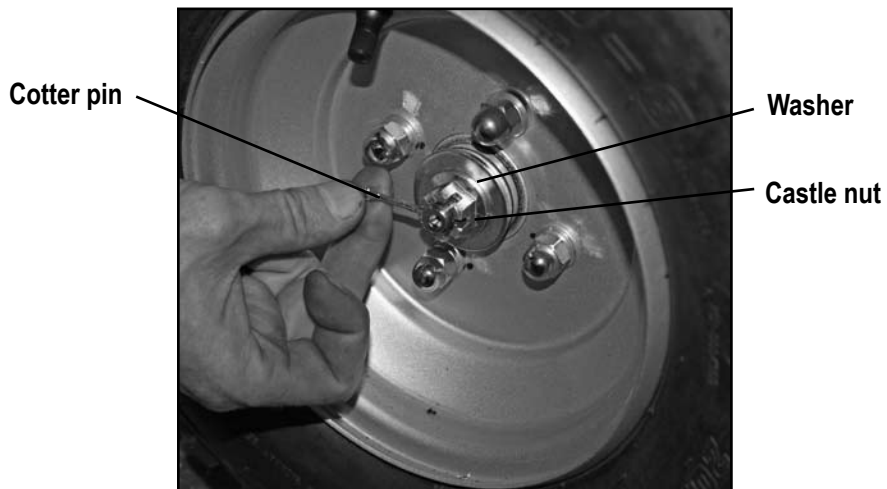

7. Attach front wheel to steering knuckle securing with washer, castle nut. Torque nut to 35ft.lbs. Install and cinch cotter pin.

Front Bumper and Front Rack

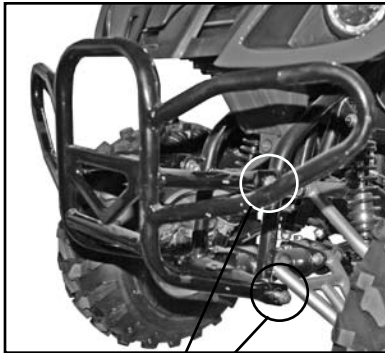

8. Attach front bumper to frame using M10x1.25x20 bolts and M10 nuts. Torque to 33ft.lbs

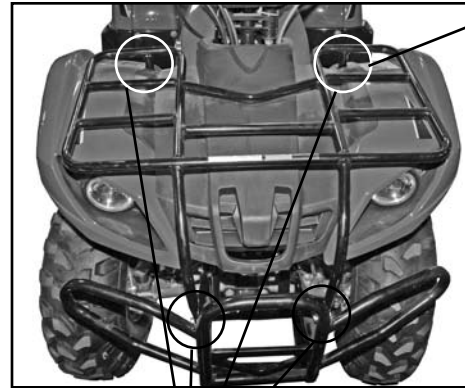

9. Attach front rack to front bumper and front fender using M8x20 bolts and M8 nuts. Torque to 17ft.lbs

Rear Rack

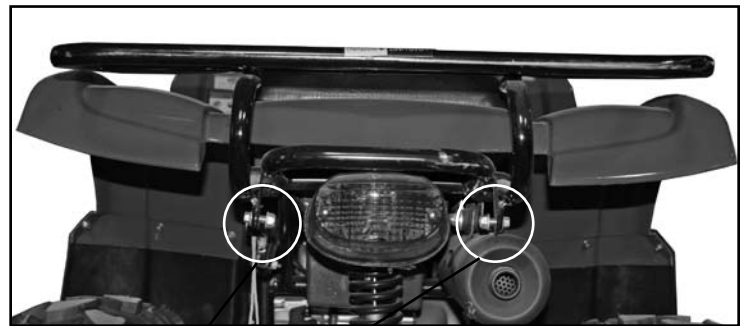
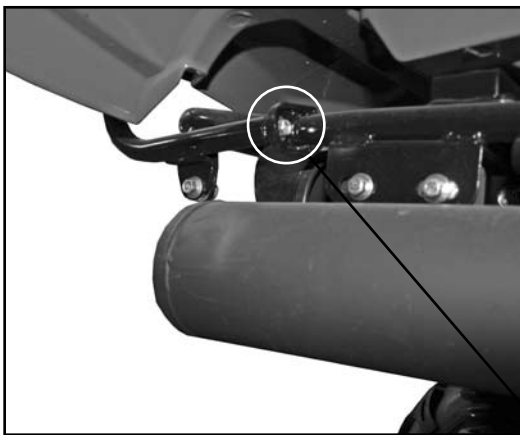

10. Attach rear rack to frame using M8x20 bolts and M8 nuts. Torque to 17ft.lbs.

Battery Installation



Eye Protection



Rubber Gloves

⚠ WARNING

The following procedure is very dangerous and should be performed with the utmost care and attention. Wear protective eye wear, rubber gloves, and have water available should electrolyte come in contact with skin or eyes. **KEEP ALL CHILDREN AWAY FROM THE AREA WHILE THIS PROCEDURE IS BEING PERFORMED.**

POISON – CAUSES SEVERE BURNS

Contains sulfuric acid.

Avoid contact with skin, eyes, or clothing

To prevent accidents, rinse empty container with water.

ANTIDOTE:

External – flush with water

Internal – Call physician immediately. Drink large quantities of water or milk.

Follow with milk of magnesia, beaten eggs or vegetable.

Eyes – Flush with water for 15 minutes and get prompt medical attention.

KEEP OUT OF REACH OF CHILDREN.

Battery Installation

Preparing the battery:

- Place battery on level surface. Remove Vent cap from battery vent located on top side portion of battery. (see figure 20)
- Remove cell caps using a pair of pliers. (see figure 21)
- Wear eye protection and rubber gloves for this step. Cut off tip of electrolyte bottle and attach tube. Place other end of tube in battery and allow the electrolyte to drain in battery cell. Fill battery to upper level mark located on front of battery. Repeat step for each of the 6 cells (see figure 22)
- After each cell is filled with electrolyte to upper level, remove tube from battery and set electrolyte aside.
- Discard empty electrolyte bottles in a waste area that is inaccessible to children and animals.
- After filling let battery stand for at least 30 minutes before charging. This allows the electrolyte to penetrate plates for optimum performance and ensures longer battery life.
- After 30 minutes the battery is ready for its initial charge. Place caps loosely over cell holes.



Figure 20



Figure 21

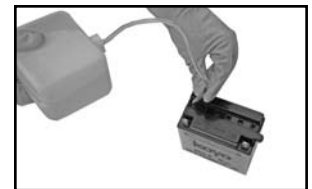

Figure 22

How to Initially Charge the battery:

1. Connect the red positive (+) cable to the red positive (+) pole of the battery. (see figure 24)
2. Connect the black negative (-) cable to the black negative (-) pole of the battery. (see figure 25)

Note: The red positive (+) cable has a larger diameter than the black negative (-) cable.

3. Charging rate: Charge battery @ 0.7 Amps for 5 ~ 10 hours.

- After charging is complete, re-install securely all six battery caps (see figure 26)
- Install battery into battery tray located under seat (see figure 27).
- Once battery is firmly seated in tray, attach red positive (+) wire to positive (+) terminal on battery, then attach black negative (-) wire to negative (-) terminal on battery (see figure 28)



Figure 24

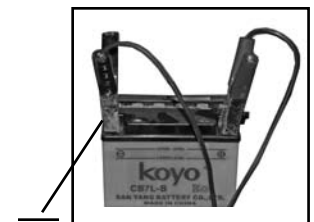

Figure 25

Install battery under seat

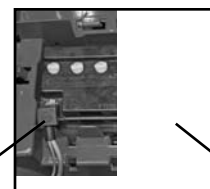

Figure 27



Figure 26

Gas and Oil

10. Fill engine with correct amount of oil. Refer to owners manual for oil type and quantity.

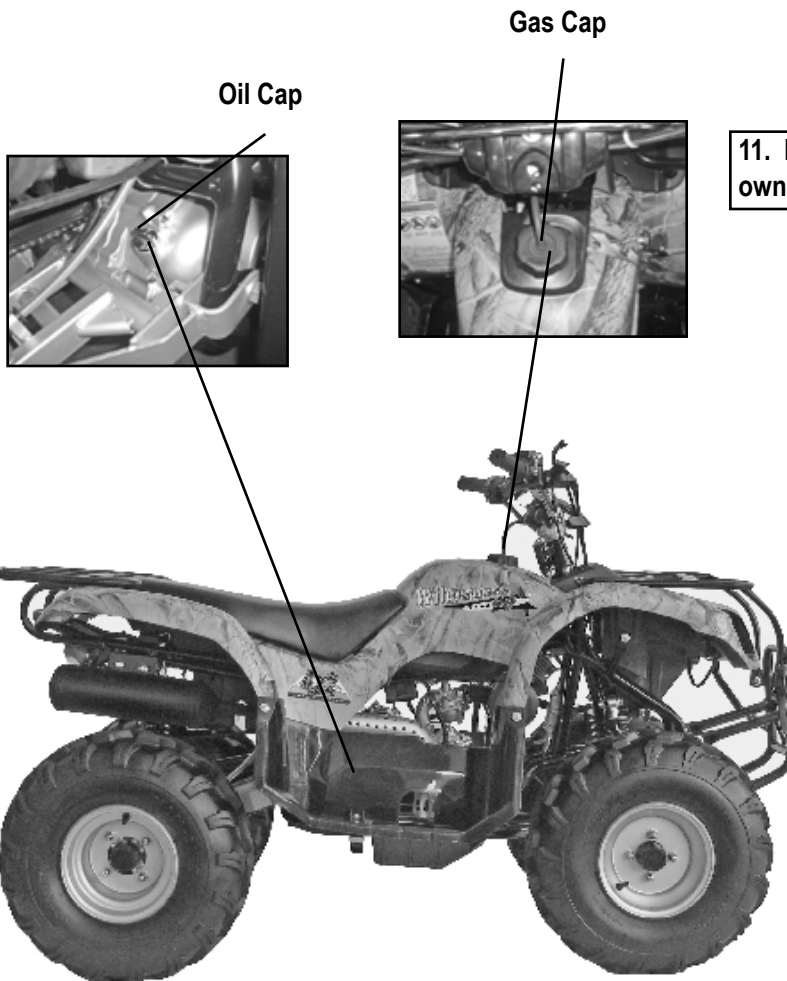

11. Fill gas tank as specified in owners manual.

12. Refer to owners manual for proper starting instructions.

CAUTION

The engine oil should be drained and replaced with new oil before starting the first time. Never attempt to start engine without first replacing engine oil with proper amount and grade as described in the owners manual.